



4K2K LCD Monitor

DM-3400

Instruction Manual

Ver.1.00



4K2K LCD Monitor

DM-3400
Instruction Manual

2008.3

Ver.1.00

ASTRODESIGN,Inc

Contents

Contents	i
Introduction.....	iii
Safety Precautions	iii
Monitor.....	iii
Power Cord.....	iv
Foreign Objects.....	iv
Power Supply and Placement.....	iv
LCD Panel.....	iv
Physical Impacts.....	v
Placement/Usage Location	v
1. About the DM-3400	1
Overview of the DM-3400	1
2. Names of Parts	3
2-1 DM-3400 Front Panel and Names of Parts.....	3
2-2 DM-3400 Base Panel and Names of Parts.....	4
3. Using the LCD Monitor.....	5
3-1 Connections	5
3-1-1 SDI Signal 8-input Connection (Total 8 Cables).....	5
3-1-2 SDI Signal 1 input Connection (Only 1 Cable)	6
3-1-3 SDI Signal 4-input Connection (Total 4 Cables).....	6
3-1-4 DVI Signal Input	7
3-2 Format Indication.....	8
3-3 Using the LCD Monitor.....	9
3-3-1 Start-Up.....	9
3-3-2 Shut-Down	9
3-4 Operation	10
3-4-1 List of Setting Items.....	10
3-4-2 Setting Sequence.....	11
3-4-3 Home Screen	12
3-4-4 DM-ID Setting Screen	12
3-4-5 Top Screen.....	13
4. Main Specifications	15
4-1 Input Formats	15
4-2 Input Signal Types.....	17
4-3 Display Type.....	17
4-4 General Specifications.....	18
4-5 Exterior View	18

5. Accessories and Options	19
5-1 Accessories	19
5-2 Options	19
6. Maintenance, etc.....	21
Troubleshooting.....	21
Conditions That Do Not Indicate a Fault or Malfunction	21
In Case of Fault or Malfunction.....	21

Introduction

Thank you for purchasing the DM-3400 56-inch 4K2K LCD monitor.

This manual describes how to operate the DM-3400 and use precautions.

Improper handling can cause accidents.

Read this manual thoroughly to ensure proper use of the DM-3400, and retain it for future reference.

Safety Precautions

Warning

Monitor

Do not subject the monitor to strong or jarring impacts. Doing so could cause fluid leakage from the LCD panel or lead to malfunction, bursting, overheating, or fire.

Do not use the monitor in locations where it could catch fire or explode.

The monitor uses high voltages internally. Do not attempt to disassemble, repair, or modify the monitor due to the risk of electric shock or burns to persons or damage to the monitor.

If you hear thunder while using the monitor outdoors, immediately power off the monitor, unplug the power cord, and move the monitor to a safe location.

Power Cord

Always grip the plug portion when unplugging the power cord.

Do not bend the power cord too tightly or bundle it. Doing so could cause a fire.

Do not place heavy objects on top of the power cord. Doing so could damage the power cord and pose a risk of fire or electric shock.

Foreign Objects

Make sure that liquids do not spill into the monitor, and do not drop flammable material or metal objects into it. Using the monitor in such a condition poses a risk of fire, electric shock, or malfunction.



Power Supply and Placement

The monitor is compatible with an AC 100 to 240 V power supply.

Use of the supplied AC cable is recommended to avoid the risk of malfunction or other problems. When using a different cable, make sure to check the power supply voltage.

Do not power on the monitor immediately after it has been powered off. Doing so could cause it to malfunction.

LCD Panel

Due to the characteristics of the liquid crystal, individual pixels may fail (remain always lit or always dark).

Do not touch any fluid that leaks from the LCD panel.

If the LCD panel is accidentally damaged, causing fluid (liquid crystal) to leak from it, do not put fluid in your mouth, swallow it, or get it on your skin. If any fluid comes in contact with the mouth or eyes, immediately flush with water. If fluid comes in contact with the skin or clothing, immediately wipe the affected area clean with a solvent such as alcohol and wash away any remaining traces with soap. Any fluid that is not removed could damage the skin or clothing.

Be careful of broken glass should the LCD panel shatter.

If the LCD panel is damaged, be careful not to cut your hands on shards of glass. Touching pieces of broken glass could result in injury.

The LCD panel is a high-precision device, so be careful regarding the following points when handling it.

- Wiping the LCD panel with solvents such as benzene or paint thinner could cause a deterioration in quality.
- Leaving water (saltwater) on the LCD panel could cause discoloration or stains.
- Leaving the LCD panel directly exposed to ultraviolet light for an extended period of time could damage the display quality of the monitor, for example by causing browning of the deflection plate and reducing the contrast.
- Introduction of moisture from sources such as condensation could cause color irregularities.
- Tapping or bumping into the LCD panel directly could crack it.

- Do not disassemble the LCD panel because leaked liquid crystal can be dangerous if it comes in contact with the skin.

Handle the LCD's protective panel with care.

To remove fingerprints or dirt from the LCD's protective panel, wipe gently with a suitable cleaning product such as one designed for office equipment. Applying too much pressure when wiping the panel could scratch or break it.

■ **When the brightness of the fluorescent lamp decreases**

Discontinue use of the LCD display if the brightness of the fluorescent lamp decreases substantially, with the color changing from white to pink. One characteristic of fluorescent lamps is that a change in the discharge color from white to pink occurs when the lamp's internal mercury becomes depleted, accompanied by a rise in the temperature at the ends of the lamp as it reaches the end of its service life. This can have a harmful effect on the module and result in permanent damage to the fluorescent lamp.

Physical Impacts

The LCD monitor is a precision device and could be damaged if subjected to physical impacts. Exercise appropriate care when moving it. Do not drop the LCD monitor.

Placement/Usage Location

Placing the LCD monitor in locations such as the following could pose a risk of malfunction or accident.

- Locations where the ambient temperature is outside the range of 10° to 40°C.¹
- Locations where the ambient humidity is outside the range of 30% to 80% RH.
- Locations subject to sudden temperature changes or condensation, such as near an air conditioner.
- Locations exposed to direct sunlight.²
- Locations with strong concentrations of corrosive gases or dust.
- Locations subject to strong magnetic fields.
- Locations where the LCD monitor could be splashed with liquids such as water, oil, or chemicals.
- Locations subject to vibrations conveyed from the floor.
- Unstable locations.

To ensure proper operation of the LCD monitor, make sure the following conditions are satisfied.

- Do not place heavy objects on top of the LCD monitor.
- Avoid placing objects in the immediate periphery of the LCD monitor.

Notes:

1. Components such as the backlight may sustain damage if the surface temperature of the LCD panel exceeds 60°C.
2. Direct exposure to ultraviolet light for an extended period of time could damage the display quality of the monitor, for example by causing browning of the deflection plate and reducing the contrast.

1

About the DM-3400

The DM-3400 is an LCD picture monitor for applications such as the development of super high-definition equipment, as a display device for digital cinema, as a display device for monitoring and other purposes, or as part of a multi-monitor display system for broadcasting stations.

It incorporates a variety of functions, including brightness and contrast adjustment, and saving and loading of setting values.

It is compatible with five types of HDTV input signals and with DVI video format input.

Overview of the DM-3400

- **56-inch a-Si TFT LCD panel**
- **(Viewing angle: 85° right-left, 85° top-bottom; 4K2K format: 3840 × 2160)**
- **Contrast ratio: 1,200 : 1**
- **Gray-to-gray response time (average): 6.5 ms**
- **Support for SDI IN and DVI IN input**
 - Supported HD-SDI specifications: SMPTE292M/294M/372M and ITU-R BT.1769 (1.485 Gbit/s SDI input)
 - Supported DVI-D signal specification: DDWG (PanelLink)
- **Support for image adjustment by the user using the remote controller**
- **Support for automatic input signal compliance (Some formats require settings by the user.)**
- **Automatic frame rate adjustment (1/1.000 and 1/1.001) and input signal detection functions**
- **AC power supply input: 100 to 240 V**

2

Names of Parts

2-1 DM-3400 Front Panel and Names of Parts

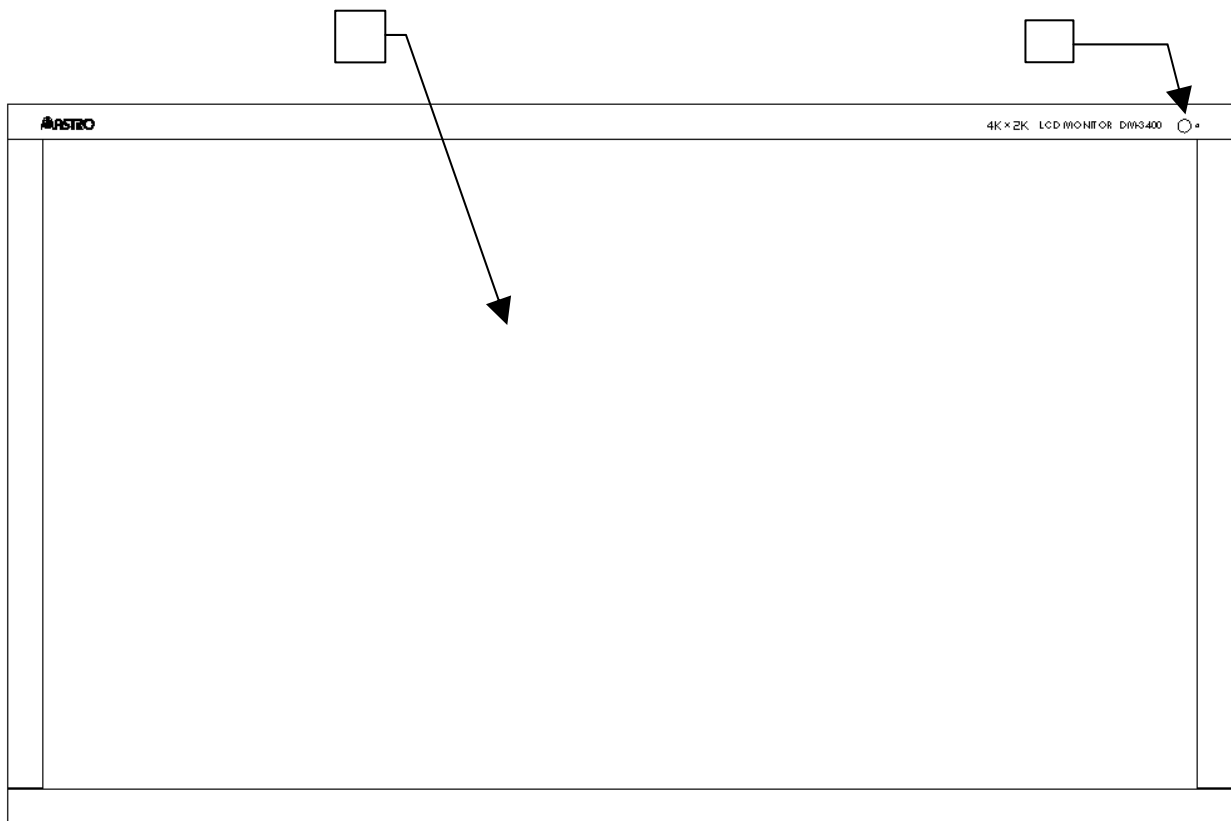

Figure 2.1 DM-3400 Front Panel

Table 2.1 Front Panel Part Names

Number	Name	Function
	<i>Infrared receiver</i>	Receives signals from the infrared remote controller (RB-1666).
	<i>LCD display</i>	Displays images.

2-2 DM-3400 Base Panel and Names of Parts

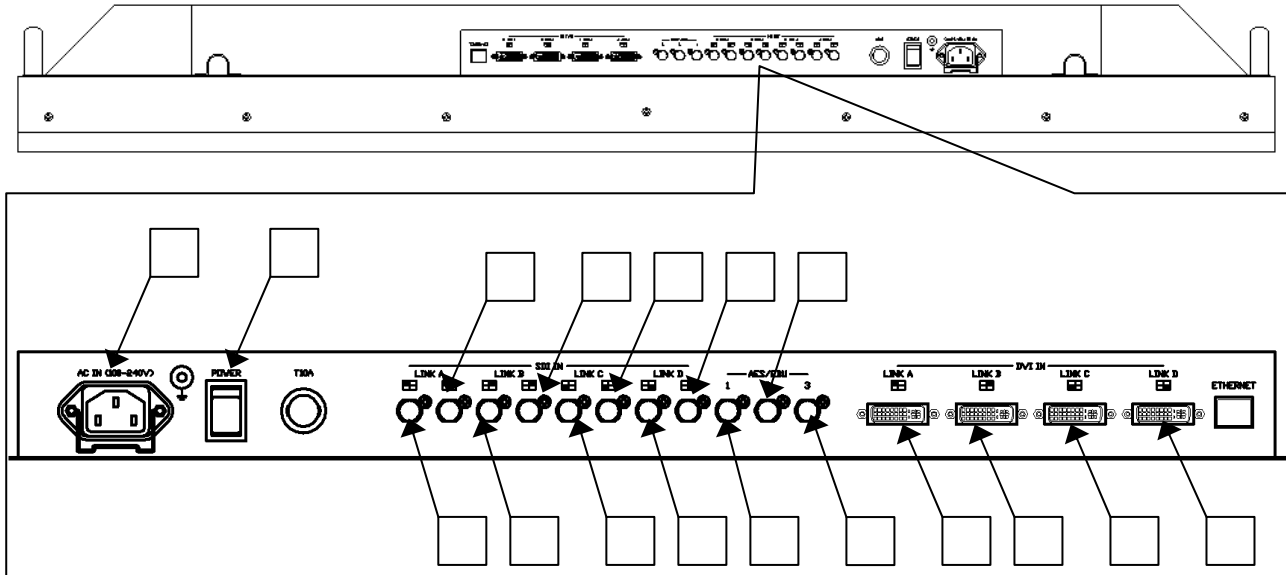

Figure 2.2 DM-3400 Base Panel

Table 2.2 Base Panel Part Names

Number	Name	Function
	<i>Power connector</i>	Connector for the AC power cable
	<i>Power switch</i>	Switches power on and off.
	AES/EBU OUT1	Coaxial audio outputs (max. 6 channels selectable).
	AES/EBU OUT2	
	AES/EBU OUT3	
	SDI area A LINK A	HD-SDI signal input jack (BNC), screen upper left, video sync
	SDI area A LINK B	HD-SDI signal input jack (BNC), screen upper left
	SDI area B LINK A	HD-SDI signal input jack (BNC), screen upper right
	SDI area B LINK B	HD-SDI signal input jack (BNC), screen upper right
	SDI area C LINK A	HD-SDI signal input jack (BNC), screen lower left
	SDI area C LINK B	HD-SDI signal input jack (BNC), screen lower left
	SDI area D LINK A	HD-SDI signal input jack (BNC), screen lower right
	SDI area D LINK B	HD-SDI signal input jack (BNC), screen lower right
	DVI LINK A	Dual-DVI signal input jack, screen top, video sync
	DVI LINK B	Dual-DVI signal input jack, screen bottom
	DVI LINK C	Not used.
	DVI LINK D	Not used.

3

Using the LCD Monitor

3-1 Connections

Connections to the DM-3400 are described below.

(1) AC cable connections

After confirming that the *POWER switch* of the LCD monitor is off, plug the AC cable (AC 100 V input) into the *power connector* (number 1 in the base panel diagram).

(2) Input signal connections

Three types of SDI input signal connections are supported: 8-input, 4-input, and single-input. Each type corresponds to a different video output format. For DVI input signals, only 4-input connection is supported.

3-1-1 SDI Signal 8-input Connection (Total 8 Cables)

Connect BNC coaxial cables (total 8 cables) to the *LINK A* to *LINK D* jacks for *SDI IN* areas A to D.

Input serial HD-SDI signals conforming to BTA S-004B.

In addition, use coaxial cables capable of handling signals in the 1.5 GHz band (5C-FB or equivalent).

The HD-SDI input signals must be serial signals conforming to the ITU-R BT.1769, BTA S-004B standard (1.485 Gbit/s).

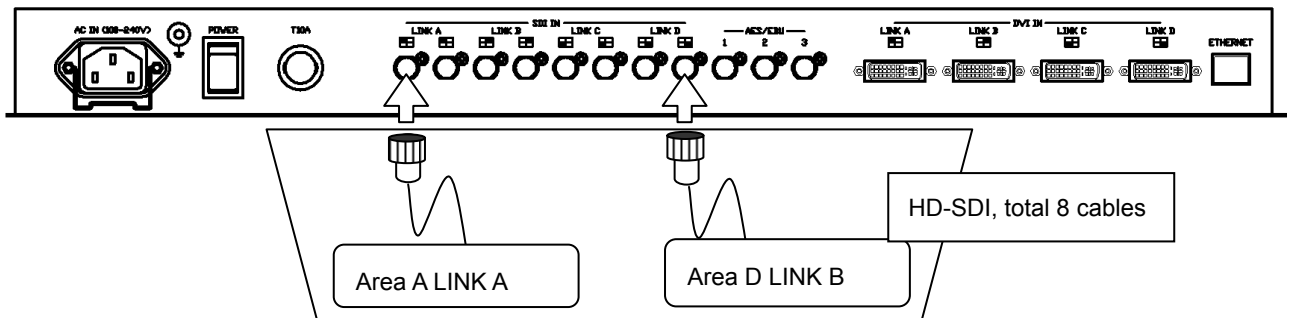

The connectors and the screen areas that correspond to them are as follows.

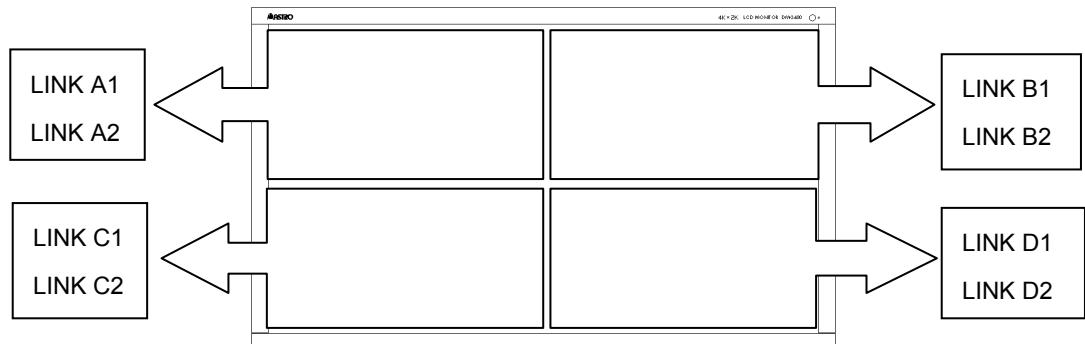

The video is synchronized based on the SDI signal input via area LINK A for area A. Therefore, if there is no LINK A signal input for area A, the entire screen cannot be synchronized.

3-1-2 SDI Signal Single-input Connection (Only 1 Cable)

Connect a BNC coaxial cable to the *SDI IN area A LINK A* jack.

Input a serial HD-SDI signal conforming to BTA S-004B.

In addition, use a coaxial cable capable of handling signals in the 1.5 GHz band (5C-FB or equivalent).

The HD-SDI input signal must be a serial signal conforming to the ITU-R BT.1769, BTA S-004B standard (1.485 Gbit/s).

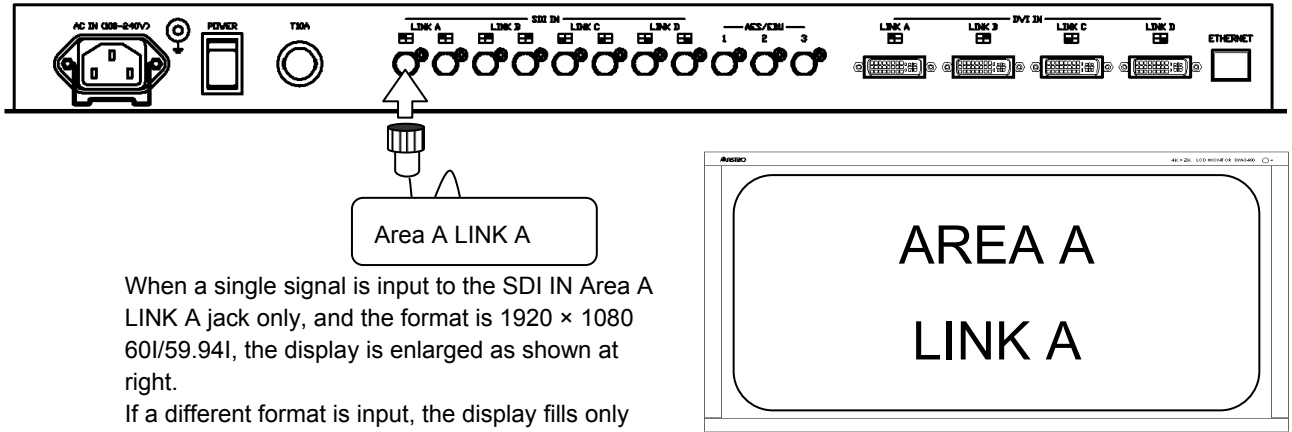

When a single signal is input to the SDI IN Area A LINK A jack only, and the format is 1920 × 1080 60I/59.94I, the display is enlarged as shown at right.

If a different format is input, the display fills only one-fourth of the screen as usual.

In this case, the DM-3400 converts the video format from interlaced to progressive (IP conversion), doubling the display size in the horizontal and vertical directions.

3-1-3 SDI Signal 4-input Connection (Total 4 Cables)

Connect BNC coaxial cables to the *LINK A* jacks for *SDI IN areas A to D*.

Input serial HD-SDI signals conforming to BTA S-004B.

In addition, use coaxial cables capable of handling signals in the 1.5 GHz band (5C-FB or equivalent).

The HD-SDI input signals must be serial signals conforming to the ITU-R BT.1769, BTA S-004B standard (1.485 Gbit/s).

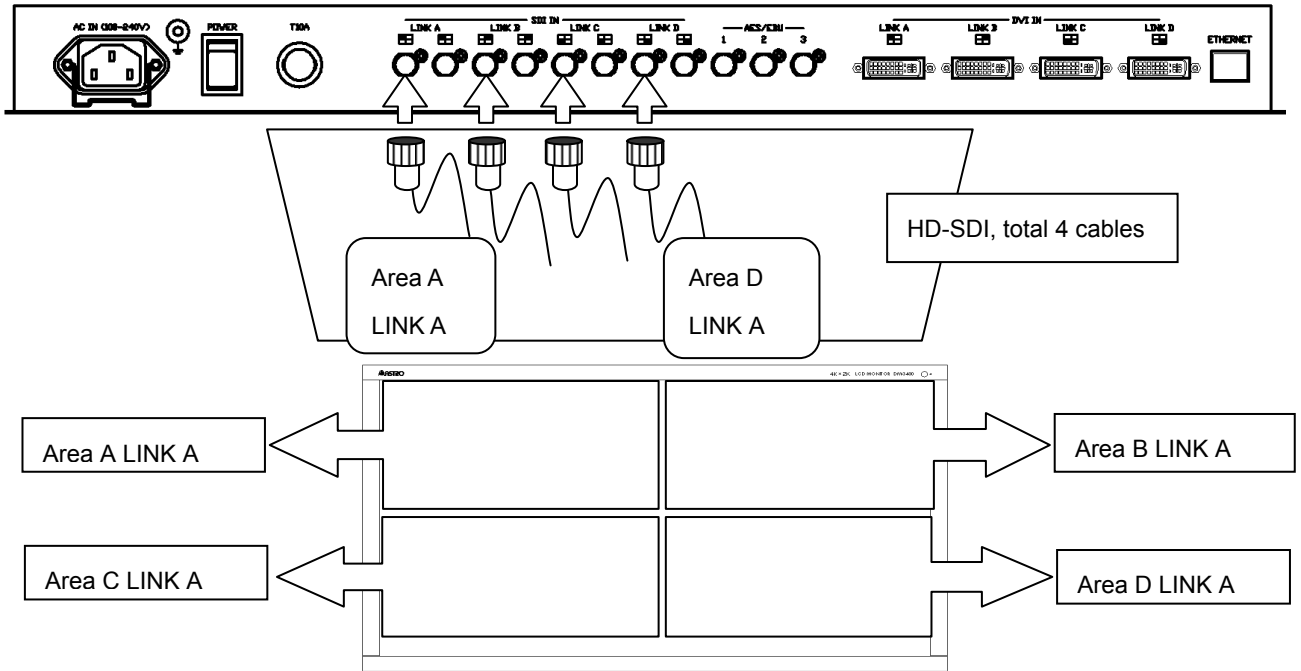

The video is synchronized based on the SDI signal input via area LINK A for area A. Therefore, if there is no LINK A signal input for area A, the entire screen cannot be synchronized.

3-1-4 DVI Signal Input

Connect Dual-DVI-compatible DVI cables to the *DVI IN area A* and *DVI IN area B* jacks. The input signals must conform to the DDWG (PanelLink) standard. Either read in an EDID or input the signals using the following timing.

< Recommended timing >

- Dot clock frequency: 297 MHz
- Horizontal active area: 3,840 pixels
- Horizontal blanking area: 560 pixels
- Vertical active area: 1,080 lines
- Vertical blanking area: 45 lines
- Horizontal back porch: 296 pixels
- Horizontal front porch: 176 pixels
- Vertical back porch: 36 lines
- Vertical front porch: 4 lines
- Hsync signal width: 44 pixels
- Vsync signal width: 5 lines

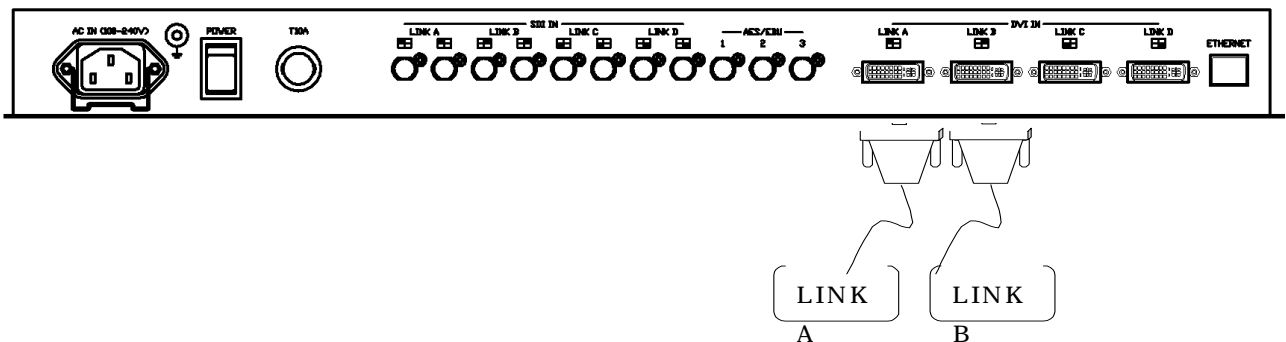

Only 2-channel (3840 × 1080) DVI signals in 60P/59.94P video format are supported.

If there is no DVI IN LINK A signal input, the entire screen cannot be synchronized.

: Bear in mind that the LCD monitor will switch to HD-SDI mode if a valid signal is input via SDI IN area A LINK A.

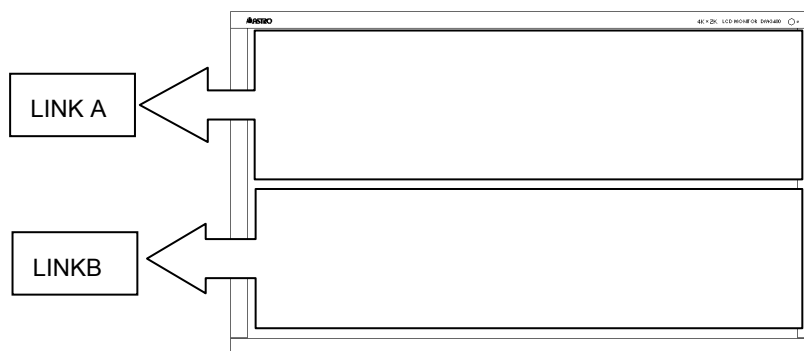

3-2 Format Indication

When a signal is input, an indication of the video format is displayed in the upper right corner of the screen.

See “4-1 Input Formats” for details of the supported formats.

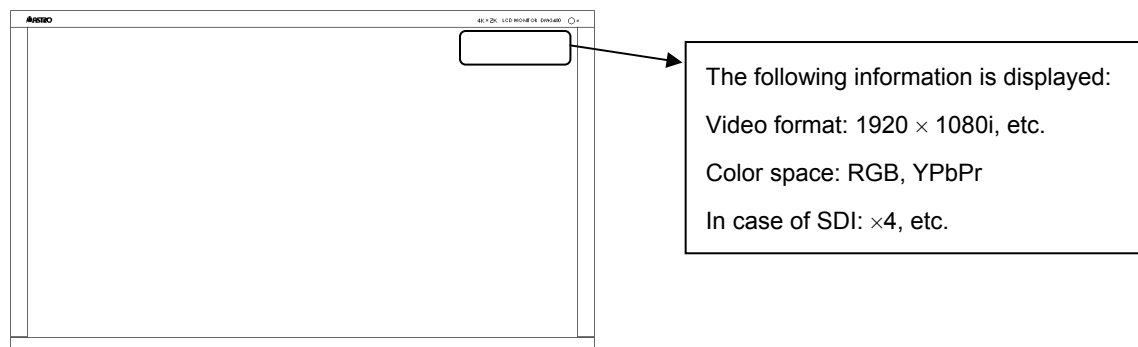

3-3 Using the LCD Monitor

3-3-1 Start-Up

The surface of the LCD panel is covered with protective film. Remove the protective film before using the DM-3400 for the first time.

Note: Always perform steps 1 and 2 in the sequence indicated when powering on the LCD monitor.

- | | |
|-------------------------------|---|
| 1 AC cable connection: | Powers on internal power supply switches, etc. |
| 2 POWER switch: | Powers on internal wiring board switches, etc. |

[Start-up sequence]

1. Confirm that the *POWER switch* is off.
2. Connect the AC cable.
3. After checking the input signal connections, turn the *POWER switch* on.
4. The *POWER LED* lights and video is displayed.

If the *POWER LED* does not light, recheck the connections.

3-3-2 Shut-Down

Note: Always perform steps 1 and 2 in the sequence indicated when powering off the LCD monitor.

- | | |
|--------------------------------|--|
| 1. POWER switch: | Powers off internal DC switches, etc. |
| 2. AC cable connection: | Powers on internal AC switches, etc. |

[Shut-down sequence]

1. Turn the *POWER switch* off.
2. The *POWER LED* goes dark and no video is displayed.
3. Unplug the AC cable.

Make all input signal connections before powering on the LCD monitor.

Do not unplug input signal cables while power is on.

3-4 Operation

By operating the RB-1666, you can change a variety of settings affecting the way video is displayed by the DM-3400. Information on the current settings is displayed in the upper right corner of the screen of the DM-3400.

3-4-1 List of Setting Items

You can change the following settings on the DM-3400 by using the RB-1666 (supplied remote controller).

- **MONITOR SETTING** These setting items affect the overall display.
 - BRIGHTNESS (brightness setting)
 - CONTRAST (contrast setting)

- **PICTURE QUALITY** These setting items allow individual adjustment of the video color information.
 - Green Bright (Green brightness setting)
 - Blue Bright (Blue brightness setting)
 - Red Bright (Red brightness setting)
 - Green Contrast (Green contrast setting)
 - Blue Contrast (Blue contrast setting)
 - Red Contrast (Red contrast setting)
 - Green Gamma (Green gamma setting)
 - Blue Gamma (Blue gamma setting)
 - Red Gamma (Red gamma setting)

- **LOAD/SAVE** This setting item is used to load and save settings.

- **OTHER**
 - Green (On: display enabled, Off: display disabled)
 - Blue (On: display enabled, Off: display disabled)
 - Red (On: display enabled, Off: display disabled)

- **DIRECT CONTROL** These items select the display mode for input in 4096 × 2160 format.
 - Color space (Top button: X'Y'Z', bottom button: RGB)
 - Scaling (Full screen) (Enter: "←" button)
 - Dot-by-dot display (Left button: move to left, right button: move to right, top and bottom buttons: sides cut off)

- **RESET** Restores the default settings.

3-4-2 Setting Sequence

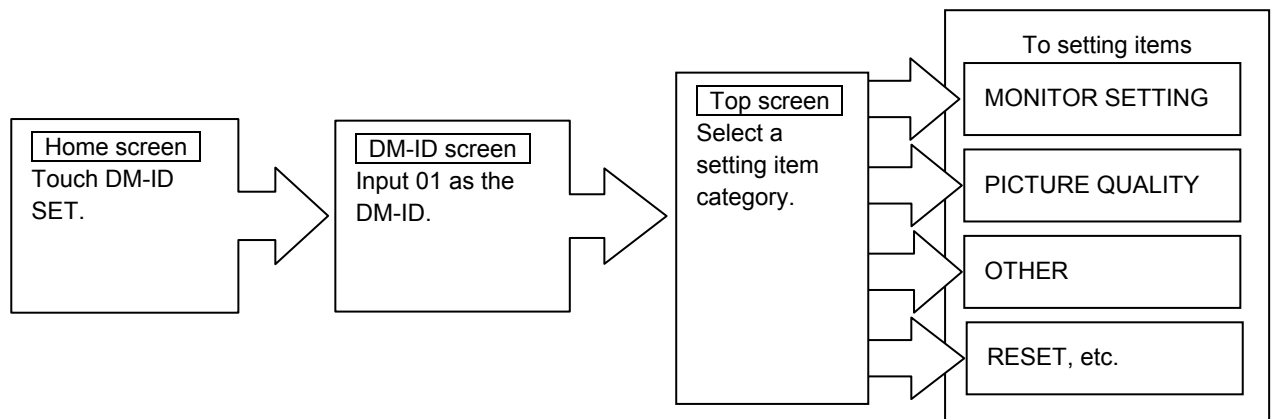

Items such as buttons for which no description is provided are not usable at this time.

They may be used for extended functions in the future.

3-4-3 Home Screen

This is the initial screen of the RB-1666. It is always displayed when starting, such as after power-on.



3-4-4 DM-ID Setting Screen

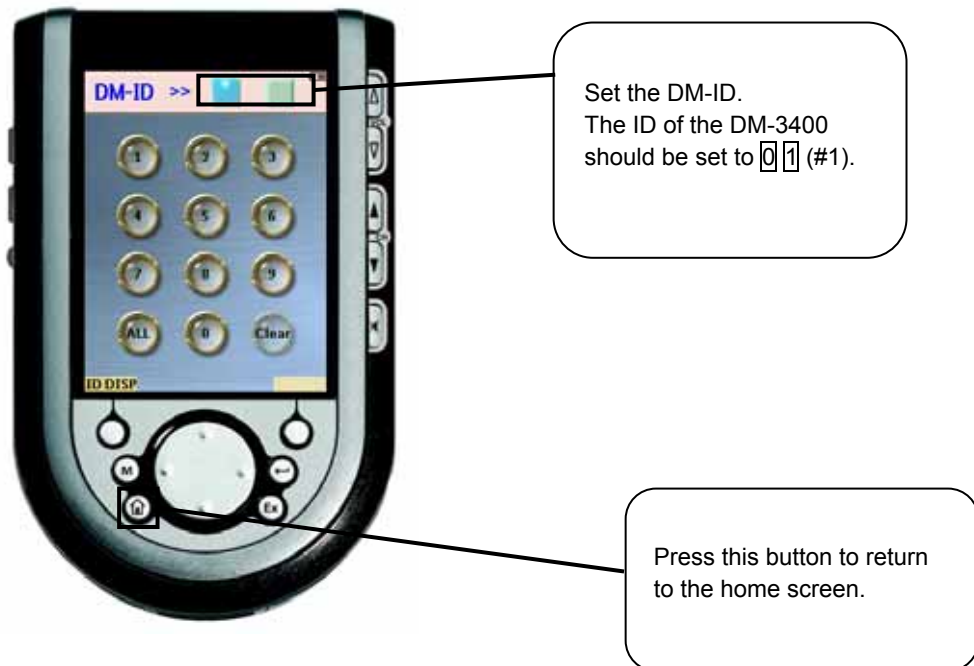

3-4-5 Top Screen

[Page 1 of Top Screen]



These setting items affect the overall display.

BRIGHTNESS (Brightness setting)
 CONTRAST (Contrast setting)

Change the settings for the individual color components.

Green Bright (Green brightness setting)
 Blue Bright (Blue brightness setting)
 Red Bright (Red brightness setting)
 Green Contrast (Green contrast setting)
 Blue Contrast (Blue contrast setting)
 Red Contrast (Red contrast setting)
 Green Gamma (Green gamma setting)
 Blue Gamma (Blue gamma setting)
 Red Gamma (Red gamma setting)

Load or save setting data.

Load: Setting data profiles Nos. 1 to 15 can be recalled.
 Save: Setting data profiles Nos. 1 to 15 can be registered.
 * At power-on, setting data profile No. 1 is used as the initial setting data.

Green (Green component enable/disable)
 Blue (Blue component enable/disable)
 Red (Red component enable/disable)



FACTORY DEFAULT Restores the default

These items select the display mode for input in 4096 × 2160 format. Use the direct keys at the bottom of the remote control to make settings.

< Display settings >

- Top button: Selects X'Y'Z' color space. (In this mode, the image is displayed dot-by-dot, and 128 pixels are cut off on the right and left sides.)
- Bottom button: Selects RGB color space. (In this mode, the image is displayed dot-by-dot, and 128 pixels are cut off on the right and left sides.)
- Left button: Dot-by-dot display with the picture moved to the left (256 pixels are cut off on the right side).
- Right button: Dot-by-dot display with the picture moved to the right (256 pixels are cut off on the left side).
- Enter button: The picture is scaled down to fit the entire screen.

4

Main Specifications

4-1 Input Formats

- HD-SDI Signals

Format Scanning 1		Frame Rate (Hz)	Color Space	Active Lines per Frame	Samples per Active Line	SDI Inputs
1080i/60	1080i/59.94	30/1.001	YPbPr	2160	3840	× 1, × 4
	1080i/60	30	YPbPr	2160	3840	× 1, × 4
1080sF/24	1080sF/23.98	24/1.001	YPbPr	2160	3840	× 4
	1080sF/24	24	YPbPr	2160	3840	× 4
	1080sF/23.98	24/1.001	RGB	2160	3840	× 8
	1080sF/24	24	RGB	2160	3840	× 8
	1080sF/23.98	24/1.001	X'Y'Z'	2160	4096	× 8
	1080sF/24	24	X'Y'Z'	2160	4096	× 8
1080p/24	1080p/23.98	24/1.001	YPbPr	2160	3840	× 4
	1080p/24	24	YPbPr	2160	3840	× 4
	1080p/23.98	24/1.001	RGB	2160	3840	× 8
	1080p/24	24	RGB	2160	3840	× 8
	1080p/23.98	24/1.001	X'Y'Z'	2160	4096	× 8
	1080p/24	24	X'Y'Z'	2160	4096	× 8
1080p/30	1080p/29.97	30/1.001	YPbPr	2160	3840	× 4
	1080p/30	30	YPbPr	2160	3840	× 4
	1080p/29.97	30/1.001	RGB	2160	3840	× 8
	1080p/30	30	RGB	2160	3840	× 8
1080P/60	1080P/59.94	60/1.001	YPbPr	2160	3840	× 8
	1080P/60	60	YPbPr	2160	3840	× 8

Note

1. Scanning format abbreviations

i: Interlaced, sF: Segmented frame, p: Progressive

▪ **DVI Signals**

Format		Frame Rate (Hz)	Color Space	Active Lines per Frame	Samples per Active Line	DVI Inputs
1080P/60	1080P/59.94	60/1.001	RGB	2160	3840	× 2
	1080P/60	60	RGB	2160	3840	× 2

The input signals must conform to the DDWG (PanelLink) standard. Either read in an EDID or input the signals using the following timing.

< Recommended timing >

- Dot clock frequency: 297 MHz
- Horizontal active area: 3,840 pixels
- Horizontal blanking area: 560 pixels
- Vertical active area: 1,080 lines
- Vertical blanking area: 45 lines
- Horizontal back porch: 296 pixels
- Horizontal front porch: 176 pixels
- Vertical back porch: 36 lines
- Vertical front porch: 4 lines
- Hsync signal width: 44 pixels
- Vsync signal width: 5 lines

4-2 Input Signal Types

Input Specification	SDI Input Specification
SDI input	ITU-R BT.1769, BTA S-004B standard compliant (1.485 Gbit/s HD-SDI input)
	Automatic field (frame) frequency selection: 60.00/59.94 [Hz]
DVI input	Supported DVI-D signal (Dual Link) standard: DDWG (PanelLink)

4-3 Display Type

Display Type	Specification
LCD	a-Si TFT
Displayable colors	16,777,216
Contrast ratio	1200 : 1
Response time	6.5 ms (typ.: gray-to-gray average)
Viewing angle	170° top-bottom, 170° right-left
Brightness	450 cd/m ² (max.)
Screen size	56 inches diagonal (196.8 (W) × 118.08 (H) (mm))
Resolution	3,840 (H) × 2,160 (V) pixels
Pixel pitch	0.108 (H) × 0.324 (V) mm

4-4 General Specifications

Table 4.1 DM-3400 (Monitor) Operating Environment and Ratings

Operating temperature range	10° to 40°C, no condensation
Storage temperature range	-10° to 60°C
Operating humidity range	30% to 80% RH (ambient temperature 0° to 40°C and no condensation)
Storage humidity range	10% to 90% RH (ambient temperature 0° to 40°C and no condensation)
Rated voltage	AC 100–240 V
Power consumption (monitor)	550 W (typ.)
Exterior dimensions	1,320 (W) × 780 (H) × 240 (D) mm
Weight	Approx. 60 kg

4-5 Exterior View

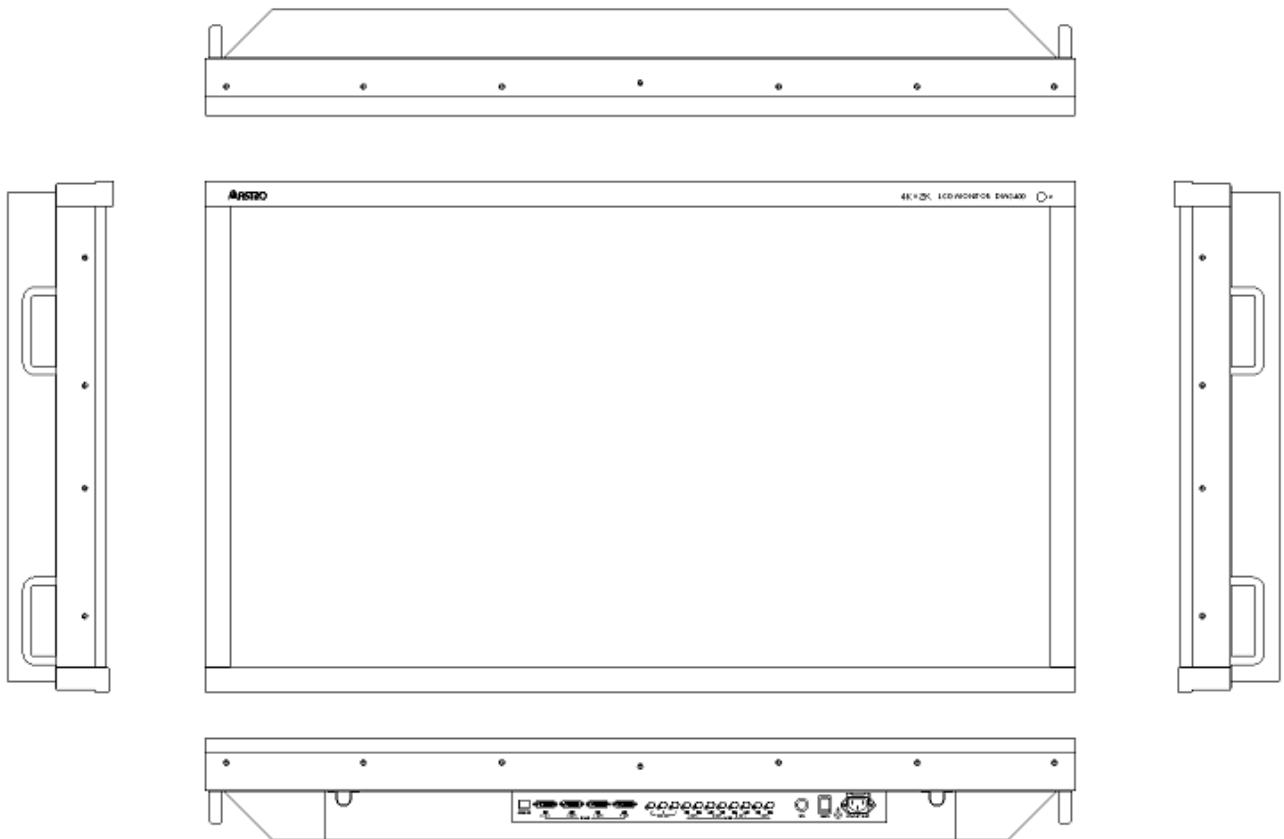

5

Accessories and Options

5-1 Accessories

DM-3400 Introduction Manual (this booklet)	1
AC cable	1
Stand (approx. 10 kg)	1
RB-1666 (remote controller)	1

[Dimensional Diagram of Stand]

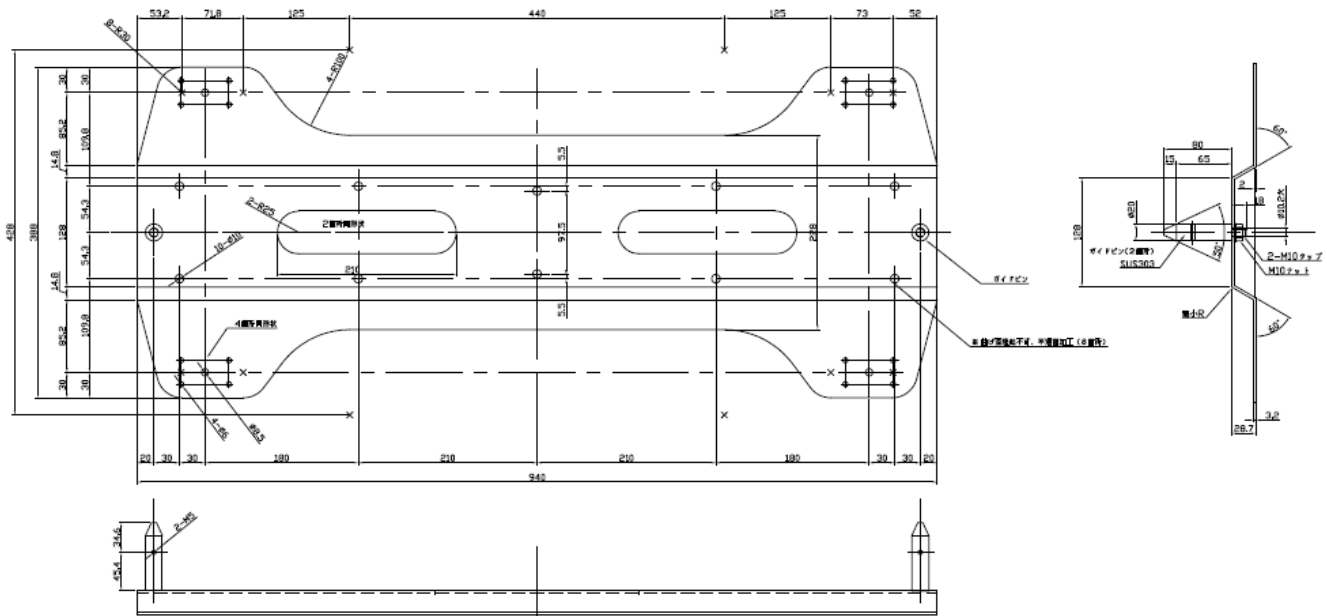

Width: 940.0 [mm]	Height: 108.7 [mm]	Depth: 388.0 [mm]
-------------------	--------------------	-------------------

5-2 Options

Options for the LCD monitor are released occasionally. Contact the ASTRODESIGN Sales Department for the latest information.

6

Maintenance, etc.

Troubleshooting

Problem	Possible Resolution
Picture does not display correctly.	<ul style="list-style-type: none">• Are the video format settings correct?• Is an erratic video signal that might trigger a CRCC or other error being input?
LCD monitor will not power on.	<ul style="list-style-type: none">• Switch power off, wait for a short while (about 3 seconds), then power the unit on again..
Poor picture quality.	<ul style="list-style-type: none">• Check the PICTURE QUALITY items for incorrect setting values.

Conditions That Do Not Indicate a Fault or Malfunction

Conditions such as the following may occur as a result of the characteristics of the LCD panel.

The response time, brightness, and color characteristics of the LCD panel may vary due to changes in the ambient temperature.

When displaying certain types of content, phenomena such as nonuniform brightness, flicker, vertical stripes, or faint spots may be visible.

The optical characteristics (brightness, display nonuniformity, etc.) of the LCD panel can change in a manner dependent on the operating duration. Such changes are particularly noticeable at low temperatures.

The display colors may appear to change with the viewing angle.

Noise may be visible on the LCD panel at startup.

Afterimages may occur in some cases. Avoid displaying static patterns for extended periods of time.

There is a delay of 1 frame between input of the video signal and its display on the LCD panel.

In Case of Fault or Malfunction

Should a fault or malfunction occur, contact the dealer from whom you purchased the LCD monitor or the ASTRODESIGN Sales Department.

A repair or replacement charge of the LCD panel will be assessed, even if the product is still under warranty.

Notes

- Manuals with missing pages or binding errors will be replaced.
- The author of this product is ASTRODESIGN, Inc.
- This manual may not be used or duplicated, in whole or in part, without permission.
- The content of this manual is subject to change without notice due to improvements.
- ASTRODESIGN, Inc., bears no responsibility for effects arising from improper use of the product.
- Direct inquiries regarding the product to the dealer from which it was purchased or to the parties listed below.
- Products and product names appearing in this manual are trademarks or registered trademarks of their respective companies.